



Start into a new era of E-Mobility  
vehicle category L3e – CR6 & CR6 Pro

**new** brand





**CR6** Pro

## THE ALL NEW CR6 & CR6 PRO

Breathtaking. Inspiring. Revolutionary. Or just fantastic. Call it whatever you want. The new CR6 & CR6 PRO are state of the art when it comes to e-mobility. After many years of development and cooperations with big players from all over the world an electric motorcycle has finally been created. It will definitely thrill you – without compromises, because charging is only needed after 120 kilometres of driving and even the performance does not come short at all. With an acceleration in only 6 sec from 0–60 km/h and a top speed of up to 105 km/h (CR6 PRO) this vehicle is revolutionary in every respect.

**brand**  
**new**



# CR6



● ● ● ●  
**CR6**

 92 km/h  120 km  134 kg

**ATTRACTIVE DESIGN,  
LATEST E-TECHNOLOGY**

# CR6 Pro



●  
**CR6 Pro**

 105 km/h  120 km  137 kg

**CENTER ENGINE WITH  
5-SPEED GEAR SHIFT**



**CR6**

**HORWIN**  
Intelligent Electric Vehicle





## LED HEADLIGHTS

Perfect sight thanks to LED technology

Low beam as well as high beam with groundbreaking LED technology will guide you the way through darkness. The lamps' light shines brighter than ever before in a perfectly clean white LED colour. Up to 28.000 Candela of light are projected by 6 LED modules through glass lenses onto the road ahead of you to ensure maximum sight under dark conditions. The result speaks for itself: 5 times better light efficiency and increased visibility compared to conventional halogen lamps known from traditional mopeds.

**By the way:** Thanks to LED technology the energy use is minimal, which will provide you with more range and power for your trip.



## FULL CONTROL

with a classic cockpit

Overview is everything. The big display of the HORWIN CR6 shows you all information which you need during your journey: topical speed, remaining reach, driving mode, temperature and a lot more. In the classical Retro design combined with the most modern technology. The background lighting shows you all infos of course also with darkness.



## NEW BATTERIES – LONGER RANGE

Lithium Ion Cells 18650 from PANASONIC

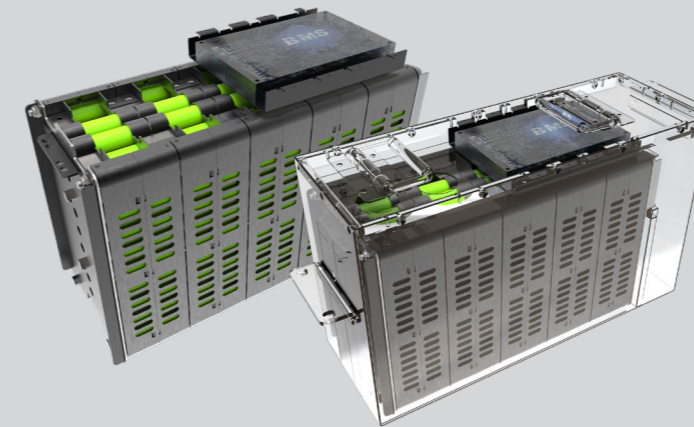

### ENDLESS POWER MEANS ENDLESS FUN.

The HORWIN CR6 uses the most modern lithium-ion batteries available. The 55 Ah battery pack is charged in approx. 3 hours from 0-80% and offers a range of up to 120 kilometres. Just like the leading car manufacturers of today, the battery cells in the CR6 are optimally armoured and protected. This does not only affect vibrations of the road surface, falling down of the motorcycle or in the worst case also falls. The integrity of the battery is not compromised even if one or more cells should fail.

### QUICK CHARGE.

Thanks to the revolutionary charging technology, you have enough charge in 20 minutes to cover a distance of 20-30km. It takes about 3 hours to fully charge the batteries. The dynamic charging process protects the cells as much as possible in order to still achieve corresponding performance values after many years.

So you can be sure that the power source of your motorcycle is always intact and working reliably. **HORWIN grants 2 years warranty on the battery!**

360° protection  
thanks to a state-of-the-art Battery Management System (BMS)



OVERLOAD



DEEP DISCHARGE



OVERVOLTAGE



OVERHEATING

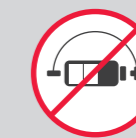

SHORT-CIRCUIT



INDIFFERENCE



## SMART CONTROLLING UNIT

the Field Oriented Control (FOC)

To find the perfect balance between range and performance, the HORWIN CR6 constantly checks your driving style and driving behavior. It's also called the „brain“ of electric vehicles, the Field Oriented Control (FOC) will monitor your requested horsepower from accelerator, transform it into smarter information and relay it – like magic – to the wheel of your vehicle. The result is simply phenomenal – the ultimate driving experience that unfortunately can not be described in words.



## CR6 – UNLIMITED PERFORMANCE

endless power means endless fun

Leave conventional petrol motorcycles behind. The HORWIN CR6 sets new standards in electric mobility with its performance-oriented combination of a brand new Field Oriented Control (FOC) and a powerful electric motor. Anyone who says „E-Mobility is no fun“; has definitely never sat on the HORWIN CR6.

6.2 kW maximum power and a top speed of 92 km/h guarantee full driving pleasure.



**CR6**

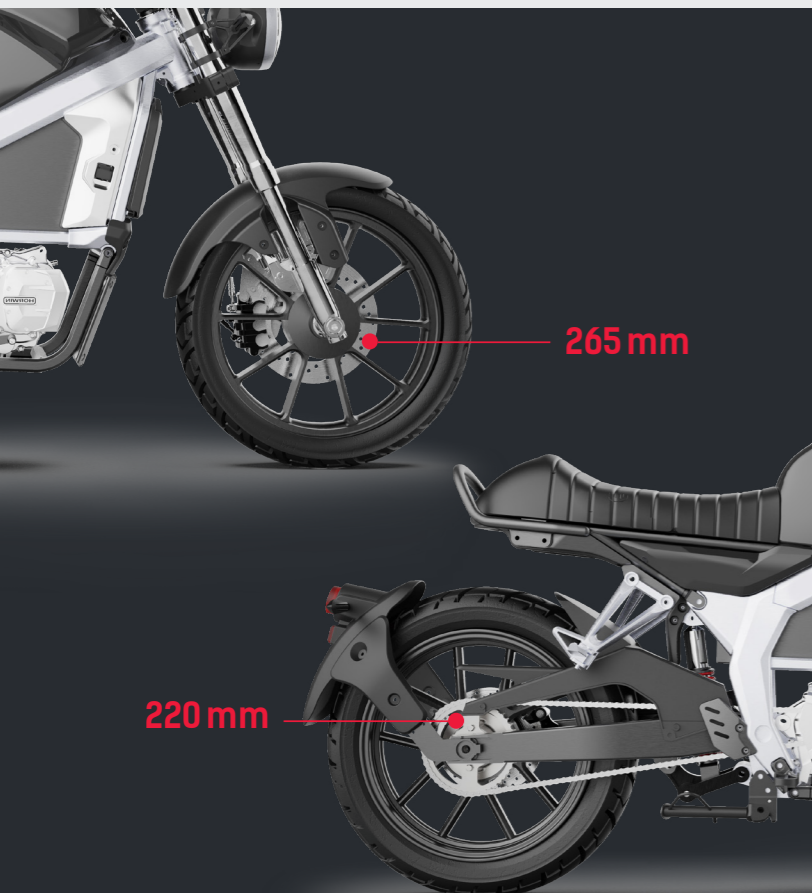

## CBS BRAKING SYSTEM

for even shorter braking distances

When you brake in an emergency, the CBS braking system will split braking force between the front and rear brake discs, reducing stopping distance and ensuring a safe brake at high speeds. The sensitive brakes allow extremely precise handling in and around corners, even in wet conditions. 265 mm perforated Brake disc front and 220 mm perforated rear brake disc guarantee safe and efficient braking in all conditions.



## CR6 PRO – NEW UNIQUE POWER

HORWIN electric motor

The newly developed HORWIN electric motor combined with the mechanical 5-speed manual transmission is probably revolutionary in this performance class. It combines pure driving pleasure combined with electric environmentally friendly drive as you only know it from conventional motorcycles. Acceleration from 0–60 in only 6 sec. and a top speed of 105 km/h are probably unique in this performance class!

**CR6 Pro**



## DEVELOPED FOR EUROPE

dimensions for the European market

Europeans are bigger and heavier – that’s why we took care during the development to adapt the seat position, seat length etc. to our requirements. Even the co-driver will find enough space on the CR6 for a relaxed ride. Take a seat and enjoy the driving experience of the new CR6.

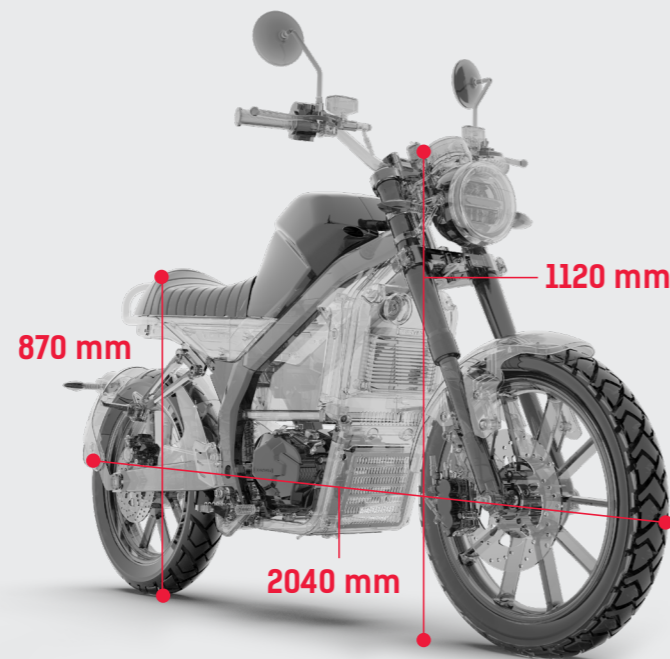

## EUROPE-WIDE E-MOBILITY SUBVENTIONS

Depending on the country you are living in, buying electric vehicles is financially supported by many governments, organisations or companies. Please get in touch with your local governmental institution to gather further detailed information. Because of this, switching to electric mobility is an absolute win-win-situation.



### NO NOISES

It drives without any noise. Even at top speed, the only thing you will hear is the tyre noise.

### NO SMELL

No exhaust gases mean no emissions. So don't worry about stinking clothes anymore.

### LOW MAINTENANCE COSTS

The HORWIN motor is completely maintenance-free. Only some parts of the brake system and the tyres need to be replaced from time to time.

## TECHNICAL DATA

		CR6	CR6 PRO
<b>ENGINE</b>	Max. power	6.2kW	11kW
	Motor type	Electric center motor permanent magnet synchronous motors	Electric center motor permanent magnet synchronous motors with 5 GEAR manual transmission
	Manufacturer	HORWIN	HORWIN
	Power management	Field Oriented Control (FOC)	Field Oriented Control (FOC)
	Max. torque	260Nm	303Nm
	Max. slope	abt. 17° at drive off	abt. 17° at drive off
	Acceleration	0-60 km/h in 6 sec	0-60 km/h in 6 sec
	Max. speed	92 km/h	105 km/h
<b>BRAKE SYSTEM</b>	CBS Disc Brake	for front and rear	for front and rear
<b>FRAME</b>	Frame	Aluminum-Magnesium Alloy	Aluminum-Magnesium Alloy
<b>MEASUREMENTS</b>	Wheelbase	1,395 mm	1,395 mm
	Length	2,040 mm	2,040 mm
	Width	770 mm	770 mm
	Height	1,120 mm	1,120 mm
	Seat height	870 mm	870 mm
	Ground clearance	165 mm	165 mm
	Net weight	134 kg	137 kg
	Front wheel	100/80-17 M/C 52S E-mark	100/80-17 M/C 52S E-mark
	Rear wheel	120/80-17 M/C 61S E-mark	120/80-17 M/C 61S E-mark
	Seats	2	2
	Max. loading	abt. 170 kg	abt. 170 kg
<b>BATTERY</b>	Battery type	Lithium Ion	Lithium Ion
	Power cells	Panasonic 18650	Panasonic 18650
	Voltage	72V	72V
	Capacity	55Ah	55Ah
	Max. range	120 km (at an average speed of 45 km/h)	120 km (at an average speed of 45 km/h)
	Charging time	3 h 0-80%	3 h 0-100%
	Charging current	220V/15A	220V/20A
<b>FEATURES</b>	Lights	LED (front, rear, flashing)	LED (front, rear, flashing)
	Display	Round Classical LCD, Automatic brightness adjustment	Round Classical LCD, Automatic brightness adjustment
	Theft warning system	Yes, electronic	Yes, electronic
	Keyless Go	Yes	Yes

### LOW OPERATING COSTS

A full charge of both batteries will cost you less than 1 € (EURO). The savings are obvious.

### LOW INSURANCE COSTS

Normally, insurance costs are much lower than for conventional petrol-powered vehicles (depending on the country).

### ENVIRONMENT-FRIENDLY

The drive of the HORWIN CR6 is probably the most sustainable and environmentally friendly way to get from A to B.



**CR6** Pro

**HORWIN**  
Intelligent Electric Vehicle





**European Headquarter**

Kammersdorf 173 | A-2033 Kammersdorf  
phone.: +43 2953 2325 | email: info@horwin.eu  
[www.horwin.eu](http://www.horwin.eu)

**HORWIN Headquarter**

Building No. 33-1&3 | Hengsheng Science & Technology Park  
Beitanghe Rd | Tianning district | Changzhou | Jiangsu  
phone.: +86 519 80585808 | email: horwin@horwinglobal.com  
[www.horwinglobal.com](http://www.horwinglobal.com)

[www.horwin.eu/cr6](http://www.horwin.eu/cr6)



**Distributor / Dealer**